

Indexing Chuck

- Used for machining workpieces with intersecting shafts, allowing all shafts to be processed in a single setup.

Examples: cross shafts, universal joints.

- During spindle rotation, simple program control is sufficient for the chuck to automatically index and position each shaft in sequence.

The hydraulic valve in the hydraulic system controls the chuck via

- a distributor installed at the tail end of the lathe bed.



[mm]

Model	D	D1	L	L1	L2	W
TK-168	190	168	142	70	35	68
TK-203	216	203	158	82	36	36
TK-225	240	225	170	95	37	37
TK-256	276	256	187	105	42	42
TK-305	330	305	212	130	45	45
TK-400	416	400	278	175	58	58
TK-460	490	460	308	205	58	58
TK-570		570	429	193.5	105	250
TK-680		680	484	239	310	300
TK-850		850	617	299	380	375
TK-1000		1000	748	339	450	420
TK-1200		1200	948	439	650	530

Indexing Chuck

<i>Model</i>	<i>Max. Workpiece Size [mm]</i>	<i>Clamping Force [kn]</i>	<i>Clamping Stroke[mm]</i>	<i>Max. RPM</i>	<i>Net Weight[kg]</i>
TK-168	136	10.6	9	70	15
TK-203	164	11.3	15.2	82	24
TK-225	190	11.3	15.2	95	30
TK-256	210	14.5	19.1	105	42
TK-305	260	14.5	19.1	130	61
TK-400	350	31.4	30	175	120
TK-460	410	31.4	30	205	161
TK-570	460	56.5	42	1200	306
TK-680	560	56.5	42	1000	412.6
TK-850	720	66.3	55	800	660.6
TK-1000	860	80.0	65	500	1298
TK-1200	1060	80.0	65	500	1558

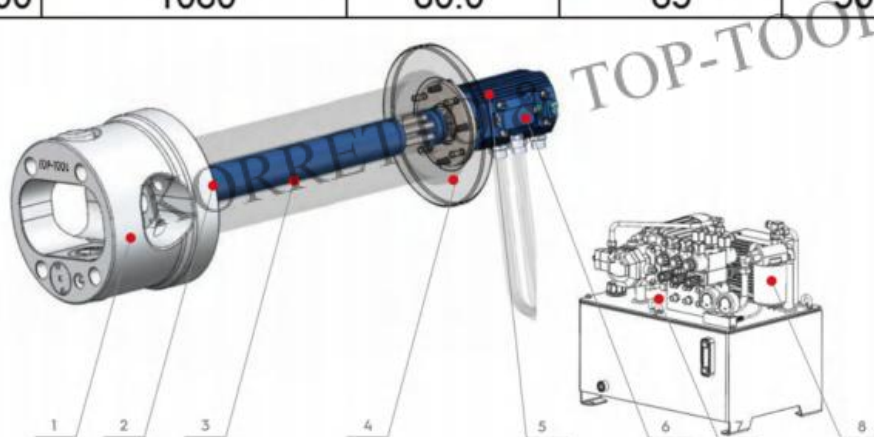

<i>NO.</i>	<i>Name</i>	<i>Function Description</i>
1	Indexing Chuck	Provides workpiece support and indexing.
2	Front Flange	Connects the spindle nose to the indexing chuck.
3	Telescopic Connecting Rod	Connects the chuck and distributor oil channels.
4	Rear Flange	Connects the distributor to the rear end of the lathe bed.
5	Distributor	Distributes and supplies oil flow during rotation.
6	Chuck Lock Alarm Mechanism	Provides position detection signals at 45° and 90°.
7	Oil Pipe Assembly	Connects the distributor and hydraulic station oil channels.
8	Hydraulic Station (Optional)	Supplies clamping support force and indexing pressure.